

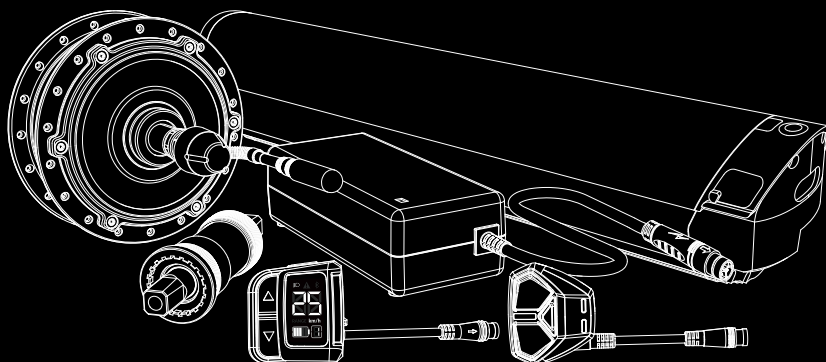

# User's Manual

## E-Metro Series



**Original Instruction**

Version 230214

Copyright © 2023 HYENA INC. All Right Reserved.





# TABLE OF CONTENTS

1.	<b>Introduction</b> .....	1
	1.1. Important notices.....	1
	1.2. Safety instructions.....	1
	1.3. Riding safety .....	2
2.	<b>E-bike system overview</b> .....	3
3.	<b>Drive unit instructions</b> .....	4
	3.1. Motor safety instructions .....	4
	3.2. Technical data of the hub motor .....	4
4.	<b>Battery handling instructions</b> .....	5
	4.1. Battery safety instructions.....	5
	4.2. Technical data of the battery .....	5
5.	<b>E-bike operation - LED Multi</b> .....	6
	5.1. HMI overview .....	6
	5.2. Technical data of the HMI.....	6
	5.3. Turning the e-bike on/off .....	7
	5.4. Select an assist level.....	7
	5.5. Charge level indicator .....	8
	5.6. Walk assistance .....	9
	5.7. Turning the lights on/off.....	10
	5.8. Bluetooth connection .....	10
	5.9. Error alert signal .....	10
6.	<b>E-bike operation - LCD Compact EX</b> .....	11
	6.1. HMI overview and display element .....	11
	6.2. Technical data of the HMI.....	11
	6.3. Turning the e-bike on/off.....	12
	6.4. Switch to speed display/range display .....	12
	6.5. Select an assist level.....	13
	6.6. Charge level indicator .....	14
	6.7. Walk assistance .....	14
	6.8. Turning the lights on/off.....	15
	6.9. Bluetooth connection.....	15
	6.10. Error alert signal .....	16
7.	<b>Charging instructions</b> .....	17
	7.1. Charging safety instructions.....	17
	7.2. Technical data of the charger.....	19
	7.3. Charging the battery.....	19
8.	<b>Storage and transportation instructions</b> .....	21
	8.1. Storage.....	21
	8.2. Charging the battery before and during storage .	21
	8.3. E-bike transportation .....	22
9.	<b>Troubleshooting</b> .....	23
	9.1. System issues .....	23
	9.2. Battery & charging issues .....	23
	9.3. Error code table .....	24
	9.4. Other issues.....	25
10.	<b>Cleaning</b> .....	26
11.	<b>Disposal</b> .....	27

# 1. INTRODUCTION

---

Thank you for choosing your new e-bike with the Hyena riding assist system. We sincerely hope that you will enjoy your ride. Please read all the safety warnings and instructions carefully. Failure to follow the warnings and instructions may result in death or severe injuries.

- This user's manual is primarily intended for the owner to operate the product.
- Save this manual for future reference.

## 1.1. Important notices

- Read and observe the safety warnings and directions in all the e-bike operating instructions.
- Users who are not professionally trained in bicycle assembly should not attempt to install, disassemble, or modify components themselves.
- If you have any concerns about the operation of the e-bike system or its components, or if you suspect damage to the battery, visit your nearest authorized bicycle brand dealer.
- The term "battery" is used in these instructions to mean all original batteries.
- Do NOT throw away this user's manual or remove any safety warning labels or instructions from any e-bike system components.

### ► About Safety Symbols

- This manual includes many "**WARNING**", "**CAUTION**" and "**NOTE**" labels; these labels refer to the safe methods to use, maintain, store, and check your e-bike.
- When a safety warning symbol is marked with "**WARNING**" text, it means failure to comply with the instructions may result in dangerous situations of death or severe injuries.
- When a safety warning symbol is marked with "**CAUTION**" text, it means failure to comply with the instructions may result in minor or moderate injury, damage to the bicycle, or the voiding of your warranty.

### ► About Images

- The e-bike images in this manual may differ visually from your Hyena system-equipped e-bike. All information provided in this manual is still applicable to your e-bike.

## 1.2. Safety instructions

### Instructions Pertaining To A Risk Of Fire, Electric Shock, Or Personal Injury

#### **WARNING**

*When using e-bikes, basic precautions should always be followed, including the following:*

- *Read all the instructions before operating the e-bike system.*
- *Close supervision is necessary to reduce the risk of injury when the e-bike is used near children.*
- *Do NOT put fingers or hands into any e-bike component or touch the cable terminal with bare hands.*

**⚠ WARNING, CONTINUED.**

- Do NOT use the e-bike if any flexible power cord or output cable is frayed, has worn insulation, or shows any other signs of damage.
- Always check the charger, cables, and power cord for any damage before charging the battery.
- Only charge the battery using an original Hyena charger.
- Do NOT immerse the e-bike or any e-bike component in water.
- Do NOT place the e-bike or any e-bike system component (like the charger) near hot, flammable objects or materials.
- The e-bike system parts are not intended to be used at ambient temperatures below -10°C (14°F) or above temperatures of 45°C (113°F).
- Defective e-bike system parts may only be replaced with identical, original genuine parts supplied by Hyena.
- Do NOT modify your e-bike system or fit any other equipment to increase the power or maximum speed of your e-bike system.

### 1.3. Riding safety

- The e-bike system provides electrical riding support. It will help you to cycle easily. Based on your riding speed and the amount of pedaling force, the e-bike system will support your efforts throughout your journey.
- When riding an e-bike, make sure that you are thoroughly familiar with the starting-off characteristics of the e-bike before riding it on roads with several vehicle lanes and pedestrian footpaths.
- When you start riding, be aware of the support the assist system will instantly provide. We advise you to drive off in a straight line, using the lowest assist level.
- Do NOT distract by the HMI or smartphone while riding. Doing this may increase the risk of being involved in an accident.
- When you switch off the riding support, select level 0 (with the system switched on), or when the battery is empty, the e-bike will ride like a regular, non-electric powered bicycle.
- The e-bike system is designed to provide riding support up to the speed limits in compliance with local regulations (e.g., 25 km/h in the EU region and 20 mph in the USA/Canada region). Do NOT modify your e-bike or fit any other equipment to increase the power or maximum speed.

**⚠ WARNING**

- When the assist system is switched on, and an assist level is selected, the riding support is activated as soon as you step onto the pedals.
- You should be seated on the e-bike and engage at least one brake before pedaling.
- With the e-bike system switched on, do NOT put one foot on a pedal and throw another leg over the bicycle, as it could accelerate unexpectedly.
- Failure to follow this warning may result in serious personal injury or even death.

## 2. E-BIKE SYSTEM OVERVIEW

The e-bike includes an electric drive and control unit; it features:

- Silent and powerful electric motor performance.
- Multi-sensor technology provides excellent, precise, and natural feeling riding support.
- Easy to operate and ergonomic HMI provides visual clarity of the e-bike status.

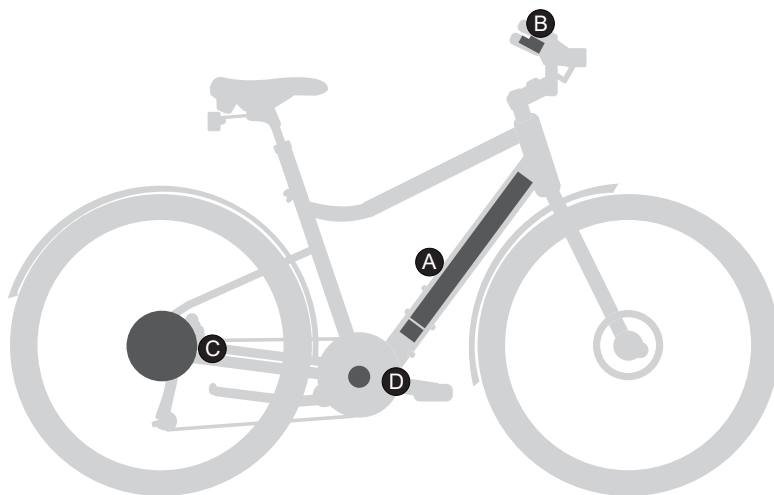
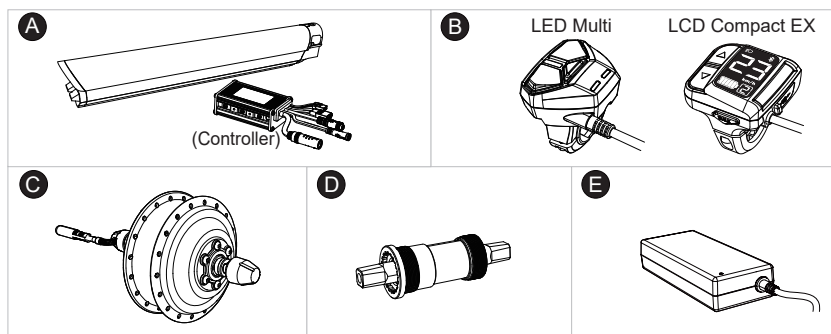

Parts	A	B	C	D	E
System	Battery	HMI	Motor	Sensor	Charger
<b>E-Metro</b>	BS-A370	LED Multi	MRT-A250	ST-SQ-1	2A /4A
<b>E-Metro E</b>	BS-A370	LCD Compact EX	MRT-A250	ST-SQ-1	2A /4A
<b>E-Metro X</b>	BS-A500	LED Multi	MRT-A250	ST-SQ-1	2A /4A
<b>E-Metro XE</b>	BS-A500	LCD Compact EX	MRT-A250	ST-SQ-1	2A /4A

### 3. DRIVE UNIT INSTRUCTIONS

Your e-bike is equipped with a 250 Watt rear-wheel electric motor, which forms the hub of the rear wheel and also provides the electric riding assistance.

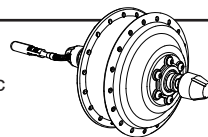

#### **⚠ CAUTION**

*Do NOT dismantle the hub motor, the hub motor should only be repaired or maintained by a certified mechanic, using genuine spare parts from Hyena.*

#### **3.1. Motor safety instructions**

- Do NOT allow the motor to suffer mechanical or physical impacts or make internal modifications.
- The motor is built with components that are sealed against dust and splashed water and can safely operate in rain and other adverse weather conditions. However, do NOT deliberately immerse the rear wheel in water or clean it with pressured water; also make sure your e-bike will get fully dry after riding in wet weather.

#### **⚠ WARNING**

- *Do NOT modify any components that are part of the bicycle drivetrain. Changing components could cause damage or overload the hub motor and may lead to serious injury or death.*
- *Do NOT obstruct pedals, cranks, or wheels when the e-bike system is on. Wrong operations could cause damage or overload the hub motor, and may lead to serious injury or death.*
- *The motor can heat up during long uphill runs. After riding, do NOT touch the metal housing of the hub motor with your bare hands or legs.*

#### **3.2. Technical data of the hub motor**

Item	Specification
Product model	<b>MRT-A250</b>
Rated voltage	36 V
Rated power	250 W
Max. torque at drive	40 Nm
Operating temperature	-10°C (14°F) to 50°C (122°F)
Storage temperature	-20°C (-4°F) to 70°C (158°F)
Protection rating	IP54
Weight (approx.)	2.7 kg (6 lbs)

## 4. BATTERY HANDLING INSTRUCTIONS

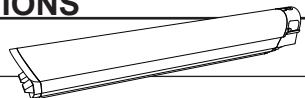

### ⚠ CAUTION

*This e-bike is powered by a Lithium-Ion (Li-Ion) battery. Always read and adhere to the instruction manual before handling or charging the battery or using the e-bike.*

### ⚠ WARNING

- *If your battery or charger exhibits any signs of damage, do NOT use the bicycle and immediately bring it to your nearest authorized bicycle brand dealer for inspection.*
- *Always turn off the e-bike system when not in use and/or when working on it.*
- *Always remove the battery during maintenance.*

### 4.1. Battery safety instructions

- Do NOT allow the battery to suffer mechanical or physical impacts or make internal modifications.
- If the battery has any visible damage, do NOT continue using the e-bike; otherwise, there will be a risk of explosion or fire and may result in severe injuries or death.
- If the battery fluid leaks out due to damage or improper usage, avoid touching the leaked battery fluid. If you accidentally touched the battery fluid, please immediately clean it with large amounts of water. If the battery fluid comes in contact with your eyes, please seek further help from physicians. Leaking battery fluids may cause burns or irritations to the skin.
- Store the e-bike in a dry and well-ventilated environment; keep the e-bike away from humid environments and water sources for battery safety.
- To avoid a short circuit between the poles, keep the battery charging socket from contact with paper clips, coins, keys, nail clippers, screws, or other objects that can generate metallic attraction.

### 4.2. Technical data of the battery

Item	Specification	
Product model	<b>BS-A370</b>	<b>BS-A500</b>
Nominal capacity	10.2 Ah	13.8 Ah
Energy	367.2 Wh	496.8 Wh
Rated voltage	36V	
Operating temperature	-10°C (14°F) to 60°C (140°F)	
Storage temperature	1 month -20°C (-4°F) to 50°C (122°F)	
	3 months -20°C (-4°F) to 40°C (104°F)	
	1 year -20°C (-4°F) to 20°C (68°F)	
Permitted charging temperature range	0°C (32°F) to 45°C (113°F)	
Protection rating	IPX4	
Weight (approx.)	2.6 kg (5.73 lbs)	2.6 kg (5.73 lbs)



## 5. E-BIKE OPERATION - LED Multi

### **⚠ CAUTION**

Before you ride:

- Regardless of your experience level, you should read this User Manual's "Introduction" chapter and carry out all essential safety checks.
- The e-bike system can only be activated when the battery is sufficiently charged.

### 5.1. HMI overview

Control the e-bike with the LED Multi HMI (CE-03), including switching on/off, selecting the level of riding support, turning the lights on/off, and using the walk assistance function.

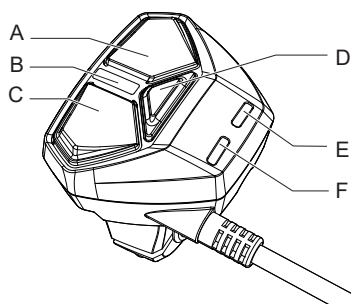

- A. Up button (Increase support level and switching on/off lights)
- B. Riding support/walk assist level indicator
- C. Down button (Decrease support level and walk assist)
- D. Power on/off button
- E. Battery charge status indicator
- F. Bluetooth/Error alert indicator

### 5.2. Technical data of the HMI

Item	Specification
Product model	<b>LED Multi</b>
Operating temperature	-10°C (14°F) to 40°C (104°F)
Storage temperature	-20°C (-4°F) to 70°C (158°F)
Protection rating	IPX5
Weight (approx.)	< 0.05 kg (< 0.11 lbs)

### 5.3. Turning the e-bike on/off

- Single press the power button to switch it on.
- Long press the power button to switch it off.

Riding with the assist system turned off is like riding a normal, non-electric powered bicycle.

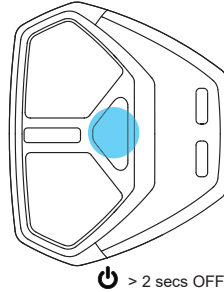
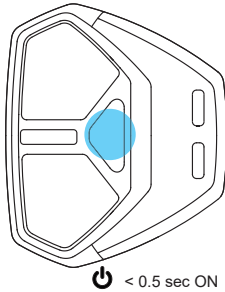

#### NOTE

- Always turn off the e-bike system after riding or when parking the e-bike.
- If the e-bike is not used and no buttons are pressed, the e-bike system will automatically turn off after six minutes to save power.

### 5.4. Select an assist level

Single press the up/down button to select the desired support level:

Level 0 (no assistance), level 1 (Eco, approx. 140% assistance), level 2 (Tour, approx. 250% assistance), or maximum level 3 (Sport, approx. 390% assistance).

#### ⚠ CAUTION

For safety reasons, always start riding at level 0 or level 1.

#### ⚠ WARNING

When learning to ride an e-bike, start at the lowest assist level and gradually increase levels.

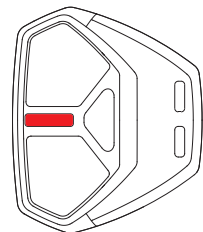
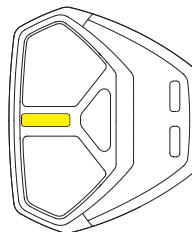
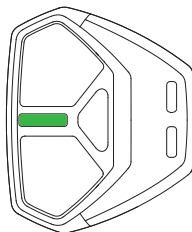
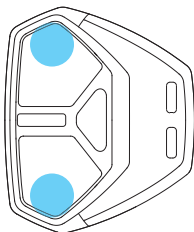

**⚠ WARNING**

*It is strongly advised to ride away in a straight line with a low support level selected. Never select assistance level 2 or 3 while maneuvering or riding away in a sharp corner. The powerful reaction of the motor might cause the e-bike to surge forward into a sharp turn resulting in a loss of balance.*

**NOTE**

- *When the e-bike system is switched on, and a support level is selected, the e-bike system is activated as soon as you start pedaling.*
- *The assist support modes affect how much support the assist system delivers based on your pedaling input.*
- *Generally, more support provides faster acceleration and easier climbing at the expense a shorter range. Lower assist levels that provide less support result in longer battery run times, longer range, and more control in situations where traction is limited.*
- *If your e-bike is equipped with gears, change gears appropriately to get, in addition to adjusting assist modes, the most use out of your battery.*
- *The e-bike drive output only supports a maximum speed as demanded by local regulation (e.g., 25 km/h in the EU region, 20 mph in the USA/Canada region); as soon as you have reached this speed limit, the e-bike suspends the riding support, then automatically reactivates when your speed comes below this.*

**5.5. Charge level indicator**

Each color of the LED on the HMI represents approximately 25% capacity.

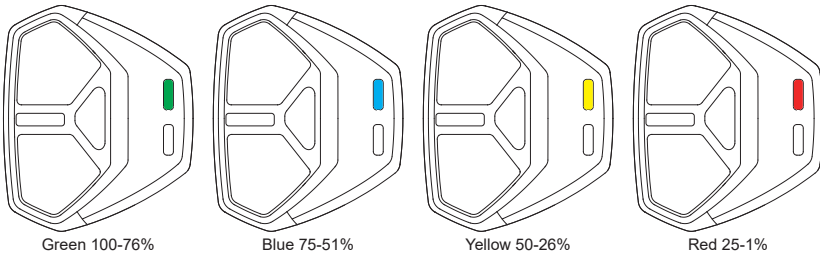

- When the battery is almost empty, the LED indicator will turn red; please charge the battery as soon as possible.
- When the battery is under 9%, the LED indicator will flash red; please charge the battery immediately.

**NOTE**

*At 4% charged, the riding support will stop. The remaining charge capacity is reserved to power the lights for up to two hours (if lights are equipped; and powered by the assist system).*

## 5.6. Walk assistance

The walk assist mode can help you push your e-bike more easily, e.g., against a slope, with a maximum speed of up to 6 km/h (4 mph).

You can only enable the walk assistance when the system is switched on, and you are pushing the e-bike.

- Long press and hold the down button on the HMI for two seconds to activate the walk assist mode.
- When the walk assist mode is activated, the assist level indicators on the HMI begin blinking.

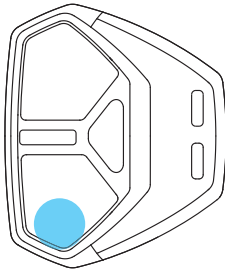

> 2 secs to activate

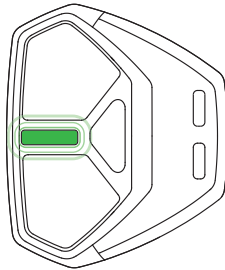

Activated

- Press and hold the up button to start the walk assist. As long as you are holding the up button, your e-bike will be propelled forward at a slow speed.
- Release the up button to stop pushing your e-bike.

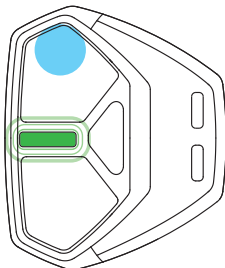

Long press to push the e-bike

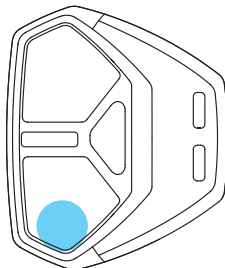

< 0.5 secs to turn off

- At the walk assist mode, if no buttons are pressed in 5 seconds, the walk assist mode will automatically turn off for safety.

### **⚠ WARNING**

- *The walk assistance function may only be used when pushing the e-bike; make sure you are ready and stand steady before activating the walk assistance.*
- *Do NOT activate the walk assistance when you ride on the e-bike or if the wheels are not in contact with the ground.*

### 5.7. Turning the lights on/off

With the system switched on, long press the up button to turn on or off the lights (if the front and rear lights are equipped and powered by the assist system).

- The battery is almost empty if the charge indicator is flashing (at < 9% charge). Charge the battery.
- At 4% charge, the riding support will stop.

The remaining charge is reserved for powering the lights (if equipped; and powered by the assist system) for up to two hours.

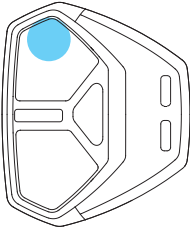

> 2 Secs

#### NOTE

- *Be aware the lighting might not work due to an empty battery.*
- *An empty battery has a reserve of maximum two hours for lighting.*

### 5.8. Bluetooth connection

With the system switched on, Bluetooth can be connected. When Bluetooth is connected to the app, the Bluetooth indicator turns blue. The Bluetooth indicator will turn back to white while Bluetooth is disconnected.

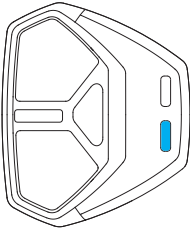

### 5.9. Error alert signal

If the error alert indicator is flashing red, please stop operating the system immediately and check the "Troubleshooting" chapter for further information and handling instructions. If the problem cannot be identified or solved, please contact your nearest authorized bicycle brand dealer.

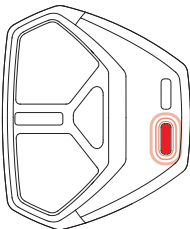

## 6. E-BIKE OPERATION - LCD Compact EX

### ⚠ CAUTION

Before you ride:

- Regardless of your experience level, you should read the “Introduction” chapter of this User Manual and carry out all important safety checks.
- The e-bike system can only be activated when the battery is sufficiently charged.

### 6.1. HMI overview and display element

Control the e-bike with the LCD Compact EX HMI (CC-02), including switching on/off, selecting the level of riding support, turning the lights on/off, and using the walk assistance function.

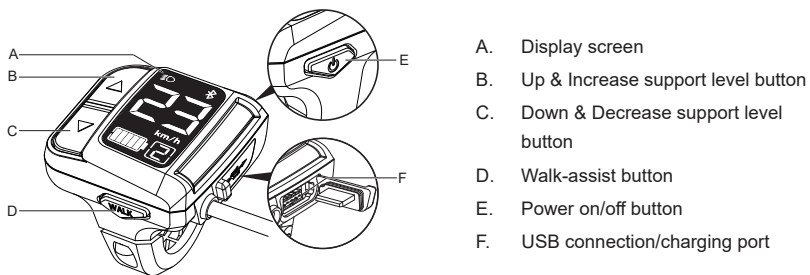

- a. Light  
 b. Error indicator  
 c. Display information type  
 d. Battery level  
 e. Bluetooth status  
 f. Speed/range  
 g. Support level

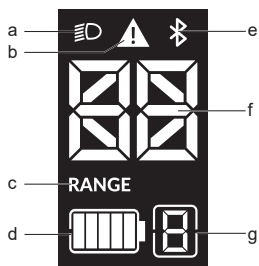

### 6.2. Technical data of the HMI

Item	Specification
Product model	<b>LCD Compact EX</b>
Operating temperature	-10°C (14°F) to 60°C (140°F)
Storage temperature	-20°C (-4°F) to 70°C (158°F)
Protection rating	IPX5
Weight (approx.)	< 0.05 kg (< 0.11 lbs)

### 6.3. Turning the e-bike on/off

- Long press the power button to turn it on/off.

Riding with the assist system turned off is like riding a normal, non-electric powered bicycle.

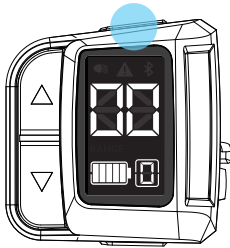

⏻ > 2 secs ON

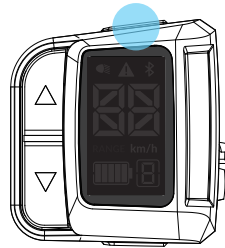

⏻ > 2 secs OFF

#### NOTE

- Always turn off the e-bike system after riding or when parking the e-bike.
- If the e-bike is not used and no buttons are pressed, the e-bike system will automatically turn off after six minutes to save power.

### 6.4. Switch to speed display/range display

Short press the power button to switch information.



0 mph

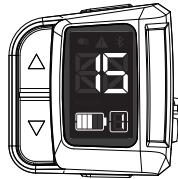

15 mph



25 mph

Speed Display



Short press  
(< 0.5 secs)



Range Display



90 miles



25 miles



When riding support  
Off range shows " - - "

## 6.5. Select an assist level

Single press the up/down button to select the desired support level:

Level 0 (no assistance), level 1 (Eco, approx. 140% assistance), level 2 (Tour, approx. 250% assistance), or maximum level 3 (Sport, approx. 390% assistance).

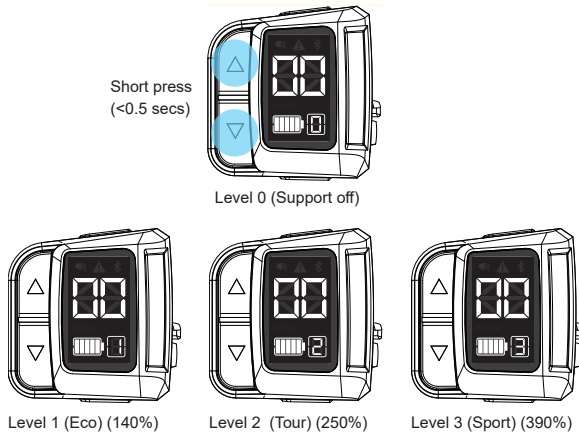

### ⚠ CAUTION

For safety reasons, always start riding at level 0 or 1 and gradually increase the levels.

### ⚠ WARNING

It is strongly advised to ride away in a straight line with a low support level selected. Never select assistance over level 2 while maneuvering or riding away in a sharp corner. The powerful reaction of the motor might cause the e-bike to surge forward into a sharp turn resulting in loss of balance.

### NOTE

- When the e-bike system is switched on, and a support level is selected, the e-bike system is activated as soon as you start pedaling.
- The assist support modes affect how much support the assist system delivers based on your pedaling input.
- Generally, more support provides faster acceleration and easier climbing at the expense a shorter range. Lower assist levels that provide less support result in longer battery run times, longer range, and more control in situations where traction is limited.
- If your e-bike is equipped with gears, change gears appropriately, in addition to adjusting assist modes, to get the most use out of your battery.
- The e-bike drive output only supports a maximum speed as demanded by local regulation (e.g., 25 km/h in the EU region, 20 mph in the USA/Canada region); as soon as you have reached this speed limit, the e-bike suspends the riding support, then automatically reactivates when your speed comes below this.



## 6.6. Charge level indicator

The icon shows the battery capacity.

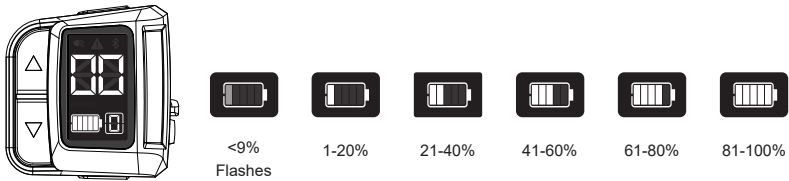

- When the battery is empty, the HMI will turn off automatically; please charge the battery as soon as possible.
- When the battery is under 9%, the battery status light will keep flashing; please charge the battery immediately.

### NOTE

*At 4% charged, the riding support will stop. The remaining charge capacity is reserved to power the lights for up to two hours (if the lights are equipped and powered by the assist system).*

## 6.7. Walk assistance

The walk assist mode can help you push your e-bike easily, e.g., against a slope, with a maximum speed of up to 6 km/h (4 mph).

You can only enable the walk assistance when the system is switched on and you are pushing the e-bike.

- Long press the “WALK” button on the HMI for two seconds to activate the walk assist mode.
- When the walk assist mode is activated, “UP” word will be displayed.

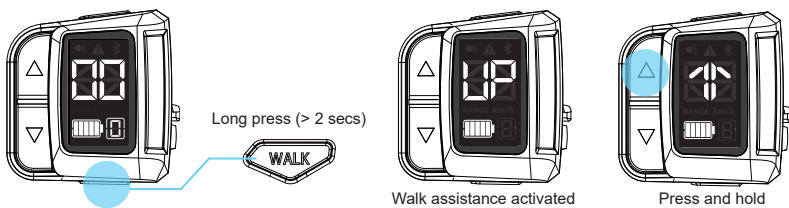

- Press and hold the up button to start the walk assist. If you hold the up button, your e-bike will slowly propel forward.
- Release the up button to stop pushing your e-bike.
- If no buttons are pressed within 5 seconds in the walk assist mode, the system will return to general mode automatically for safety. Or if the “down/walk” button is pressed in the walk assist mode, the system will also return to the general mode.

**⚠ WARNING**

- *The walk assistance function may only be used when pushing the e-bike; make sure you are ready and stand steady before activating the walk assistance.*
- *Do NOT activate the walk assistance when you ride on the e-bike or if the wheels are not in contact with the ground.*

**6.8. Turning the lights on/off**

With the system switched on, long press the up button to turn the lights on/off. The light indicator on the upper-left corner of the display will light up.

- If the charge indicator is flashing (at < 9% charge), the battery is almost empty. Charge the battery.
- At 4% charge, the riding support will stop. The remaining charge is reserved for powering the lights (if equipped and powered by the assist system) for up to two hours.

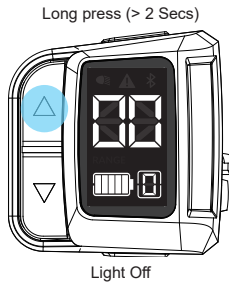

**NOTE**

- *Be aware that lighting might not work due to an empty battery.*
- *An empty battery has a reserve of maximum two hours for lighting.*

**6.9. Bluetooth connection**

With the system switched on, Bluetooth can be connected. When Bluetooth is connected to the app, the Bluetooth indicator on the upper-right corner of display will light up.

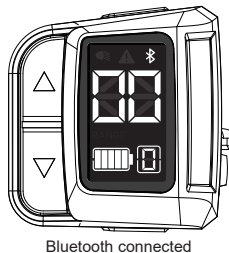

## 6.10. Error alert signal

If the error alert indicator on the upper-mid corner of display lights up, please stop operating the system immediately and check “Chapter 9 Troubleshooting” for further information and handling instructions. Please contact your nearest authorized bicycle brand dealer if the problem cannot be identified or solved.

- In alert mode, the error alert indicator will flash, and an error code will be displayed.
- After 3 seconds, the display will return to the general mode (range/speed display) for 10 seconds, then go back to the error alert and loop continuously.

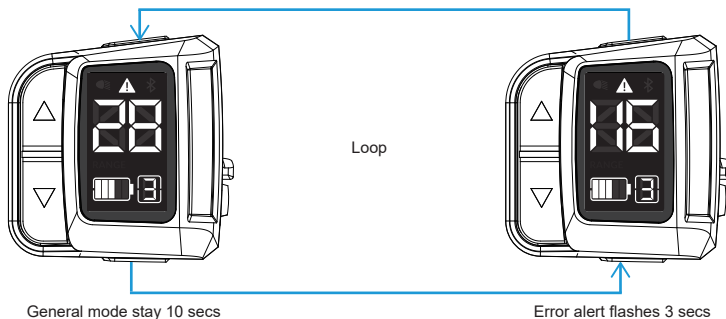

- Short press (< 0.5 sec) any button to suspend the error code display circulation. The error alert indicator will keep showing on the display until the error is solved.

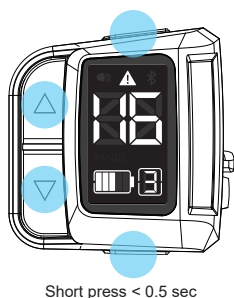

- When you switch off the e-bike and turn it back on, the error alert indicator and error code will be displayed again until the error is solved.

## 7. CHARGING INSTRUCTIONS

---

### 7.1. Charging safety instructions

#### **⚠ CAUTION**

- *The e-bike battery cannot be used immediately after shipment; to ensure that it has full and sufficient power, please charge your battery fully before using it for the first time.*
- *For battery health and safety reasons, the e-bike battery will automatically turn into sleep mode if its charge is below 70% and it has not been used for over 72 hours. Please charge the battery again to wake it up.*

#### **⚠ WARNING**

- *Only charge the battery by following all safety instructions in this manual and on the battery and charger labels.*
- *Please read and follow the instructions for using the battery charger.*

#### **► About charging**

- Charge the battery indoors at room temperature to avoid exposure to heavy rain or strong wind. Do NOT use the charger outdoors or in environments with high humidity.
- When charging, make sure the e-bike and the charger are on a fireproof surface.
- When possible, you should charge the battery in an area with a smoke detector or make sure someone is paying attention during the charging process.
- Do NOT try to use the e-bike or charge the battery if the battery has any signs of damage.
- Avoid moving the battery while it is charging.  
The battery charger's power plug may come loose and not be fully inserted into the electrical outlet, resulting in a fire risk.
- Do NOT leave the charger plugged in the e-bike for more than 24 hours. If the charging is not complete in 24 hours, contact your nearest authorized bicycle brand dealer for assistance.

#### **► About the chargers**

- Only use chargers provided by Hyena. Using an uncertified battery charger may result in severe injuries or even death.
- Do NOT place the battery charger at locations that are easily accessible to children.
- Do NOT place the battery charger on the floor or in other dusty places when using it.
- Place the battery charger on a stable, fireproof surface such as a table when using it.
- Do NOT place any objects on top of the battery charger or its cable.  
Do NOT place a cover on it either.
- Do NOT use the battery charger with commercially available electrical transformers designed for overseas use (travel converters). They may damage the battery charger.
- Be sure to hold the power plug steady instead of holding the cord when connecting or disconnecting from the electrical outlet. Failure to do so may damage the cord and/or plug and cause an electric shock or a fire.

### ► About the chargers, continued

- When charging the e-bike, be careful not to trip over the charger cord. This may lead to injury or cause the bicycle to fall over, damaging the components.
- Do NOT touch the metallic parts of the device, the power plug on the AC adapter or other parts when the charger is wet, electric shocks may occur.

### ► About the wall socket, and cord

- Do NOT apply excessive tension to the cables and charging plugs.
- Use only a 100V to 240V AC electrical outlet, do NOT overload the electrical outlet with appliances beyond its rated capacity.
- If the electrical outlet is overloaded by connecting too many appliances using adapters, overheating resulting in fire may occur.
- Do NOT damage the power cord or power plug. Do NOT damage, process, forcibly bend, twist, pull, or bring the power cord or power plug near hot objects, place heavy objects on them or bundle them tightly together. If they are used while damaged, fire, electric shocks, or short-circuits may occur.
- The charger is equipped with a cord having an equipment-grounding conductor and a grounding plug. The plug must be plugged into an outlet with a circuit breaker that is properly installed and grounded in accordance with all local codes and ordinances.
- In the event of a charging malfunction, grounding provides a path of least resistance for electric current to reduce the risk of an electric shock.

#### **⚠ WARNING**

*Improper connection of the equipment grounding conductor is able to result in a risk of an electric shock. Check with a qualified electrician if you are in doubt as to whether the product is properly grounded. Do NOT modify the plug provided with the product - if it will not fit the outlet, have a proper outlet installed by a qualified electrician.*

### ► About defects

Stop using the device and contact your nearest authorized bicycle brand dealer if the following symptoms are observed.

- The heat or acid-smelling smoke is coming from the power plug.
- There may be a bad connection inside the power plug.
- Suspect any other defect.

### ► About the battery life

- The battery is a consumable item. The battery will gradually lose its capacity for charging after repeated use and after time has passed. If the length of time or the riding distance that the battery can be used becomes extremely short, it has probably reached the end of its life. Purchase a new battery.
- The life of the battery will vary depending on factors such as the storage method, the usage conditions, the surrounding environment, and the characteristics of the individual battery pack.

## 7.2. Technical data of the charger

Item	Specification	
Product model	Charger 2A	Charger 4A
Charging current (max.)	2A	4A
Rated Input voltage	100-240VAC	
Input frequency range	50-60 Hz	
Rated output voltage	42±0.2 V	
Charging time (approx.)	BS-A370: 5 hours BS-A500: 7 hours	BS-A370: 2.5 hours BS-A500: 3.5 hours
Permitted charging temperature range	0°C (32°F) to 40°C (104°F)	
Storage temperature	-20°C (-4°F) to 55°C (131°F)	

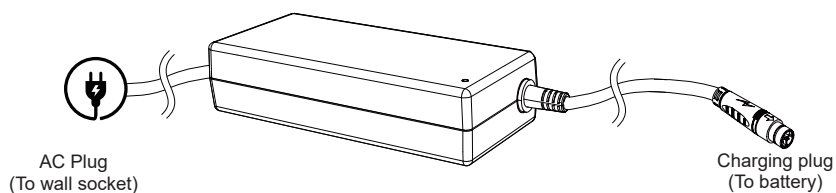

## 7.3. Charging the battery

### ► Before charging

- Regularly inspect the charging socket and charger for damage. Never charge the battery, or use the e-bike, when you suspect it to be damaged or broken.
- Make sure the outlet and AC plug of the charger are undamaged and dry before connecting and charging the battery.

### ► Indicator on charger

- During the charging process, the LED indicator on the charger will illuminate red.
- When the battery is fully charged, the LED indicator on the charger will turn green.

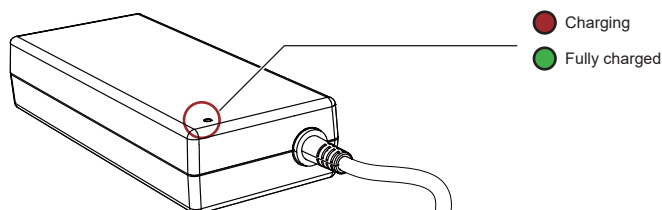

### ⚠ CAUTION

*If the red LED indicator flashes during the charging process, a charging error has occurred. In that case, immediately remove the charger from the socket. Discontinue the use of the assist system and contact your local authorized bike shop.*

#### NOTE

- *The battery is equipped with a Battery Management System (BMS), which is designed to protect a fully discharged battery from damage for a period of time. However, to maintain the best possible battery performance and lifespan, Hyena recommends regularly recharging your battery to at least 80% of the total capacity.*
- *The Li-ion batteries gradually lose capacity depending on age and use. A strongly reduced operating time after charging can be a sign that the battery is reaching the end of its useful life and has to be replaced.*

#### ► Charging procedure

- The battery can always be charged, regardless of the current charge level.
- The charging can be interrupted at any moment. Interrupting the charging process will not damage the battery.
- Please perform charging in environments between 0°C (32°F) to 40°C (104°F).

#### ⚠ CAUTION

*Always turn off the assist system while charging.*

1. Open the cover of the charging socket on the e-bike.
2. Connect the charging plug to the charging socket on the battery.

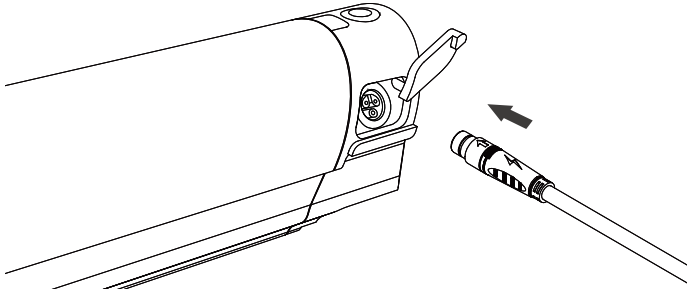

3. Plug the AC plug of the charger into an outlet (100V to 240V). The LED on the charger will illuminate red while charging.
4. While charging, the charge level indicator on the HMI will show the charge level of the battery. Each illuminated green LED on the HMI represents approximately 20% capacity. The battery is fully charged when the indicator on the charger turns green and all green LEDs on the charge level indicator on the HMI illuminate.

**Note.** *The e-bike system will power off after reaching full charge (within about six minutes).*

5. After charging, disconnect the AC plug from the outlet and the charging plug from the battery.
6. Close the cover to protect the charging socket.

## **8. STORAGE AND TRANSPORTATION INSTRUCTIONS**

### **8.1. Storage**

- During storage, it is not recommended to have the battery permanently connected to the charger.
- Store the e-bike and the battery in the following locations: in a dry, well-ventilated room with a smoke alarm, away from combustible or easily flammable objects, and away from heat sources.
- Store the e-bike and battery on a fireproof surface without contact with water, heat sources, or sand. Protect the battery against moisture and water.
- Do NOT store the e-bike and battery at ambient temperatures less than -20°C (-4°F) or above ambient temperatures of 50°C (122°F).
- For a long battery life, however, storing the battery at room temperature of approx. 20°C is of advantage.
- Protect the e-bike from sunlight damage if you store it at any place for more than a week.
- Do NOT place any heavy items on the e-bike or any e-bike components.

#### **⚠ CAUTION**

*If the battery is stored lacking charge, the battery may be damaged due to deep-discharge, also the charge capacity itself may be affected significantly.*

### **8.2. Charging the battery before and during storage**

- If you are not using the e-bike for an extended period, charge the battery to 80% to meet the optimum storage condition.
- Recheck the charge status again after six months; if the battery's remaining charge is less than 30%, charge it to 80%.



### 8.3. E-bike transportation

- Do NOT place the e-bike in the car boot for more than one day.
- Protect the e-bike from damage by sunlight.
- An e-bike is heavier than a normal bike. If transporting on a vehicle, be aware of the maximum load capacity of the vehicle's roof, towing hook and/or of the applied bike carrier.
- Always respect local laws about the transportation of an electric bicycle.
- As the size and power of this Li-Ion battery are considered as 'Dangerous goods, class 9,' you may be restricted in the transport of separate Li-Ion batteries in some places when transporting.
- The restrictions apply to most airlines and some courier companies. But, if you intend to ship or travel with your complete e-bike (with installed battery), the regulations are less strict. Check ahead with your airline or carrier before booking your trip to ensure you can travel with your complete e-bike.
- The e-bike, including batteries, is subject to legislation on the transporting of dangerous goods. Private users can only transport undamaged batteries by road without complying with additional requirements.

#### **⚠ CAUTION**

*Shipping of all types of (loose) batteries, including lithium-ion and lithium-metal types, may require the use of specialized packaging, specific hazard labeling, and specific documents certifying compliance with the applicable local regulations.*

## 9. TROUBLESHOOTING

---

When your e-bike has issues, you can check the following instructions for basic troubleshooting. If the problem cannot be identified or solved, please contact your nearest authorized bicycle brand dealer.

### 9.1. System issues

- **System cannot be turned on**
  - **Check the battery charge status:** If the battery charge is low or if the battery is even empty, please recharge the battery with a certified charger.
  - **Check the cable connection:** Check all external cable connections are correctly connected. If external connections are all correctly connected, please contact your nearest authorized bicycle brand dealer for further inspection.
- **No assistance power**
  - **Charge level:** check the charge level; at 4% battery charge and below, the riding support will stop. The remaining charge is reserved to power the lights (if equipped and powered by the assist system) for up to two hours.
  - **Check your riding assist level on the HMI:** You will only feel the riding support from level 1 to level 3.
  - **Pedal the e-bike:** The e-bike only provides riding support power when you keep pedaling. Riding support will be shut down immediately when you stop pedaling.
  - **System overheats:** Are you riding on long slopes in the heat or put an overload weight on your e-bike for a long time? The e-bike assist system may overheat. Please turn off the system, then take your e-bike to a well-ventilated area and let it cool down for at least 10 minutes.
  - **Speed limitation:** The e-bike drive output only supports to a maximum speed as demanded by local regulations; as soon as you have reached this speed limit, the e-bike system suspends the riding support, then automatically reactivates when your speed is below the speed limit.
- **The lights do not illuminate**
  - Check the charge level of the battery, and charge it if necessary.  
When the battery charge is below 4%, the remaining amount is reserved for powering the lights for up to two hours. At 0% charge, the lights will not illuminate anymore.
  - Check if all the connectors of the electric cables are correctly connected.  
If you are not sure, contact your nearest authorized bicycle brand dealer.

### 9.2. Battery & charging issues

- **The battery quickly loses energy**
  - The battery may be near the end of its service life. Contact your nearest authorized bicycle brand dealer for further service.
  - The battery capacity may be affected by ambient temperature, especially in cold weather.
- **The battery cannot be charged**
  - Check if the connection terminals of the charger plug and charging socket at the charge port are clean; if not, wipe them clean with a dry cloth.

- Securely connect the charging adapter to the battery charging port and charge again. If the battery still does not charge, consult your nearest authorized bicycle brand dealer.
- **The LED indicator on the charger does not illuminate.**
  - Turn on the e-bike system; if the battery charges correctly, the charge indicators on the HMI will flash and show the current charge status.
  - Disconnect and then reconnect the power plug of the charger, and then repeat the charging operation.

If the LED indicator on the charger still does not illuminate, contact your nearest authorized bicycle brand dealer.

### 9.3. Error code table

If your e-bike is equipped with LCD Compact EX or when you use Hyena Rider Assistant smartphone app, the error code shows on the screen when a system error is detected. You can check the recommended action below for basic troubleshooting. Contact your nearest authorized bicycle brand dealer for service if the error still exists.

Code	Category	Error Details	Troubleshooting
16	Torque sensor	Torque sensor voltage too high	Check the sensor cable connection
17		Torque sensor voltage too low	Check the sensor cable connection
32	Motor	Motor voltage too high	Check the motor cable connection
33		Motor voltage too low	
34		Motor hall U phase malfunction	
35		Motor hall V phase malfunction	
36		Motor hall W phase malfunction	
37		Phase U malfunction	
38		Phase V malfunction	
39		Phase W malfunction	
40		Motor temperature too high	Stop riding for 10 minutes
48	Speed sensor	No speed signal	Check the motor cable connection
49		No cadence signal	Check the sensor cable connection
50	Chain	No chain	Check the chain status
64	Battery	Battery voltage too high	Remove and place the battery back
65		Battery voltage too low	Charge the battery
66		Low battery capacity	
67		Flat battery	
68		Charging temperature too high	Move to an area with proper temperature
69		Battery cell temperature too low	
70		Battery cell over temperature	Contact your nearest authorized bicycle brand dealer
71		Battery over discharged	
72		Battery over charged	
73		Battery over discharged error	
74		Battery over charged error	Contact your nearest authorized bicycle brand dealer

Code	Category	Error Details	Troubleshooting
80	Controller	Controller temperature too high	Stop riding for 10 minutes
81		Battery communication fail	Contact your nearest authorized bicycle brand dealer
82		Pedal rotation blocked	Reboot the e-bike system
83		Handle rotation blocked	Contact your nearest authorized bicycle brand dealer
84		Controller communication fail	
85		High side FET of U phase malfunction	
86		Low side FET of U phase malfunction	
87		High side FET of V phase malfunction	
88		Low side FET of V phase malfunction	
89		High side FET of W phase malfunction	
90		Low side FET of W phase malfunction	
91		FET malfunction	
92	FET over current protection		
96	Others	Throttle assist voltage too high	Check the cable connection
97		Throttle assist voltage too low	
98		Button blocked	Contact your nearest authorized bicycle brand dealer
99		Button communication fail	
100		Display panel malfunction	
101		USB charge port malfunction	
112		Front light malfunction	Check the cable connection
113		System maintenance notify	Contact your nearest authorized bicycle brand dealer
114		Bluetooth malfunction	
116		Rear light malfunction	

#### 9.4. Other issues

Contact your nearest authorized bicycle brand dealer if your e-bike does not work correctly due to mechanical problems, assist system issues or any other situation that cannot be identified or solved.

## 10. CLEANING

---

- When cleaning, disconnect the power plug from the electrical outlet and the charging plug from the battery. If this is not observed an electric shock may occur.
- Do NOT immerse the e-bike system or any individual e-bike component in water.
- Do NOT clean any assist system component with pressured water.
- Only clean the product with a water-dampened soft cloth.
- Do NOT clean any assist system component with any detergent or organic solvent.
- The system is designed to operate in rain and other adverse weather conditions. Damage due to pressure washing or other heavy cleanings may void the warranty.

## 11. DISPOSAL

- The e-bike assist system drive unit including the motor, controller, battery, sensor, HMI, wiring, accessories, and packaging should be disposed of in an environmentally correct manner according to local rules.
- Do NOT dispose of e-bikes and their components with household waste.



### Information on Waste Disposal for Consumers of Electrical & Electronic Equipment

This mark on a product and/or accompanying documents indicates that when it is to be disposed of, it must be treated as Waste Electrical & Electronic Equipment (WEEE).

Any WEEE marked waste products must not be mixed with general household waste, but kept separate for the treatment, recovery and recycling of the materials used.

For proper treatment, recovery and recycling; please take all WEEE marked waste to your Local Authority Civic waste site, where it will be accepted free of charge.

If all consumers dispose of Waste Electrical & Electronic Equipment correctly, they will be helping to save valuable resources and preventing any potential negative effects upon human health and the environment, of any hazardous materials that the waste may contain.



### Please recycle your spent batteries

Batteries should not be disposed of in unsorted municipal waste, but separately collected to facilitate the correct treatment and recycling of the substances they contain. The recycling of batteries ensures the recovery of these valuable materials and prevents any potentially harmful effects upon both the environment and human health.

Please contribute to battery recycling by segregating all spent batteries and actively participating in their collection and recycling. Various battery collection schemes will be in operation in different areas of the country. However, battery collection bins will be available at retail stores that sell batteries as well as at schools, libraries and other public buildings.

### **⚠ WARNING**

*Failure to follow the instructions in this section may cause damage to the components on your e-bike. It will void your warranty but, most importantly, may result in serious personal injury or death.*

**SAVE THESE INSTRUCTIONS**



Hyena Inc.

Tel +886 4 23598810

Fax +886 4 23598610

[www.hyena-ebike.com](http://www.hyena-ebike.com)

Address No.25, Jingke N. Rd., Nantun Dist., Taichung City 408, Taiwan (R.O.C.)